



48500 Kato Road
Fremont, CA 94538 USA

Product Specification

2x8 Coherent Mixer with Single-Ended PD Output

Part No.:
RX-GC50AP201

Revision: **1.3**

Page 1 of 12

Dual-Polarization Coherent Mixer with Single-Ended PDs

P/N: [RX-GC50AP201](#)

Revision History

Rev.	Date	Revision History	Originated	Signed by
1.0	4/12/2013	Initial Release	Tao Yu	Jindong Li
1.1	4/17/2013	Corrections: Tight buffer for SMF, Loose tube for PMF	Tao Yu	Yigao Sha
1.2	6/10/2016	<ul style="list-style-type: none">Added a note below Table 4.3 to specify the single-end PD as Kyosemi KPDE030-SRevised Corporate address to 48500 Kato Road	Stephanie Hung	James Pang
1.3	12/30/2016	Replaced Figure 1.2 with an actual product photo	Stephanie Hung	James Pang



48500 Kato Road
Fremont, CA 94538 USA

Product Specification

2x8 Coherent Mixer with Single-Ended PD Output

Part No.:
RX-GC50AP201

Revision: **1.3**

Page 2 of 12

Table of Contents

1. INTRODUCTION	3
1.1. DESCRIPTION	3
1.2. FUNCTIONAL DIAGRAM.....	4
1.3. PORT DEFINITION.....	4
2. ABSOLUTE MAXIMUM RATINGS	5
3. OPERATING CONDITIONS	6
4. OPTICAL-ELECTRICAL SPECIFICATIONS	7
4.1. BEGIN-OF-LIFE SPECIFICATION	7
4.2. END-OF-LIFE (EOL) OPTICAL SPECIFICATION.....	8
4.3. PD CHARACTERISTICS.....	10
5. PHYSICAL REQUIREMENTS	11
5.1 MECHANICAL DRAWING	11
5.2 PORT ASSIGNMENT.....	11
5.3 FIBER AND PIGTAIL REQUIREMENTS.....	12
6. LABEL REQUIREMENTS	12
7. QUALITY AND RELIABILITY	12



48500 Kato Road
Fremont, CA 94538 USA

Product Specification

2x8 Coherent Mixer with Single-Ended PD Output

Part No.:
RX-GC50AP201

Revision: **1.3**

Page 3 of 12

1. Introduction

1.1. Description

This document defines the requirement of a special coherent receiver with 8 single-ended photodiode outputs, per customer request.

The coherent mixer, consisting of two polarization-diversified 90deg optical hybrids, a polarizing beam splitter and a beam splitter, is exactly same as existing DP-QPSK coherent mixer, and therefore offering same optical performance.

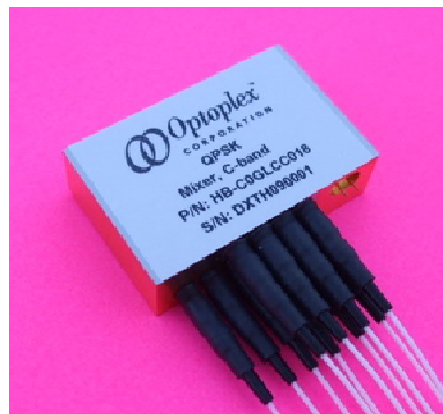

Figure 1.1, Optoplex's existing 2x8 DP-QPSK Coherent Mixer

To achieve the required configuration, functionalities and performance, 8 individual single-ended photodiodes are used to replace the 8 output collimators in the existing coherent mixer design.

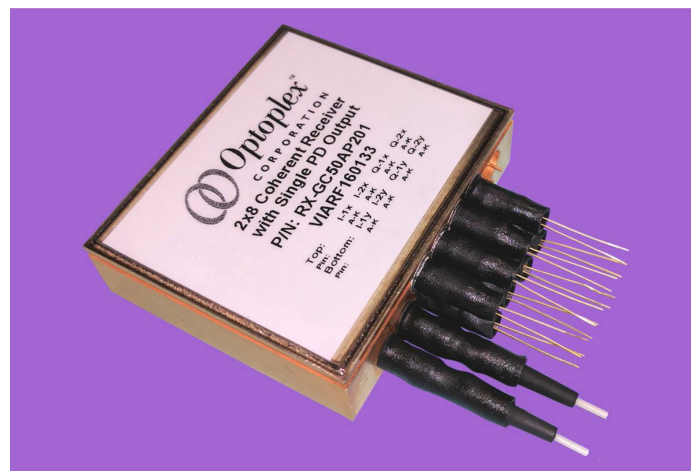

Figure 1.2, Optoplex 2x8 coherent receiver with 8 single-ended PD outputs

The requirements and specification of the 2x8 coherent are described in following sections.

This document and its entire contents are proprietary and confidential to Optoplex. Neither this document, nor any part of it, may be disclosed or conveyed to, used by or copied for, any third party without the prior written consent of Optoplex. © Optoplex. All rights reserved.

1.2. Functional Diagram

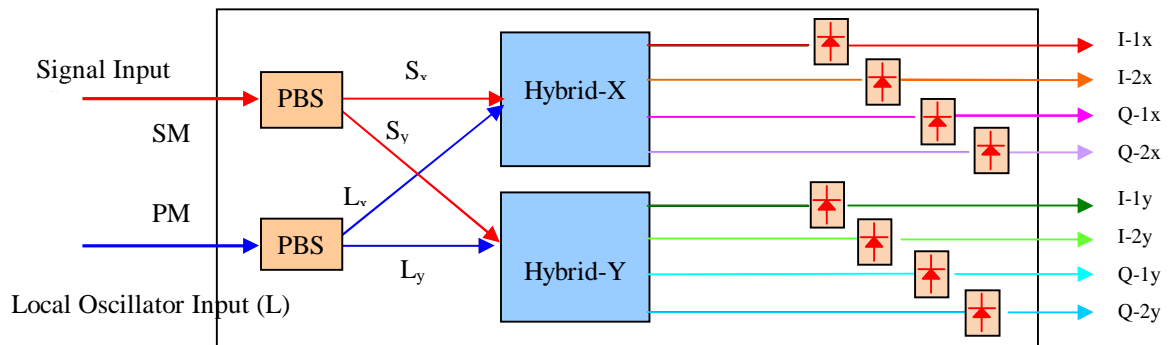

Figure 1.3, Functional block diagram of the coherent receiver with single-ended PD output

Per customer's request, the 8 single-ended photodiodes are completely independent of each other – each one has its own and separate ground to provide the user the flexibility for independent monitoring and control.

1.3. Port Definition

Port	Function	Phase Difference	Polarization	Value	Note
1	Local			L	
2	Signal			S	
3	I-1x	0	x	$S_x + L_x$	
4	I-2x	π	x	$S_x - L_x$	
5	Q-1x	$\pi/2$	x	$S_x + jL_x$	
6	Q-2x	$3\pi/2$	x	$S_x - jL_x$	
7	I-1y	0	y	$S_y + L_y$	
8	I-2y	π	y	$S_y - L_y$	
9	Q-1x	$\pi/2$	y	$S_y + jL_y$	
10	Q-2x	$3\pi/2$	y	$S_y - jL_y$	

Table 1.1, Port Definition



48500 Kato Road
Fremont, CA 94538 USA

Product Specification

2x8 Coherent Mixer with Single-Ended PD Output

Part No.:
RX-GC50AP201

Revision: **1.3**

Page 5 of 12

2. Absolute Maximum Ratings

Table 2.1, Absolute Maximum Ratings

Item	Parameter	Symbol	Condition	Min	Max	Unit
1	Storage temperature range	T_{stg}		-40	85	°C
2	Storage humidity	RH_{stg}	Non Condensing	5	95	%
3	Accumulated maximal optical input power	P_{opt_max}	Continuous wave only on Local input W/O Signal	17	-	dBm
			Continuous wave only on Signal input W/O Local	17	-	dBm
4	Photodiode bias voltage	V_{PD_max} V_{MPD_max}		-0.3	5.6	V
5	Photodiode (reverse) bias current	I_{PD_max} I_{MPD_max}	Per photodiode		5	mA
6	Electro static discharge (ESD) voltage	V_{ESD}	Positive and negative pulses	250	-	V
			$C = 100\text{pF}; R = 1.5\text{ k}\Omega; \text{Human Body Model}$			



48500 Kato Road
Fremont, CA 94538 USA

Product Specification

2x8 Coherent Mixer with Single-Ended PD Output

Part No.:
RX-GC50AP201

Revision: **1.3**

Page 6 of 12

3. Operating Conditions

Table 3.1, Operating Conditions

Item	Parameter	Symbol	Condition	Min	Typ.	Max	Unit
1	Operating case temperature range	T_{case}		-5		65	°C
2	Relative humidity range	RH	Long Term, non condensing	5		90	%
3	Operating frequency range	λ	C- Band	1525		1568	nm
5	Signal input power level	P_{signal}		-18	-10	0	dBm
6	LO power level	P_{LO}		8		16	dBm
7	Polarization of input light	Signal input		Polarization multiplexed, phase modulated, random input polarization state			
		Local oscillator input		Linear polarized, continuous wave, aligned with slow axis of PMF			
12	Photodiode bias voltage	V_{PD}		4.75		5.25	V



48500 Kato Road
Fremont, CA 94538 USA

Product Specification

2x8 Coherent Mixer with Single-Ended PD Output

Part No.:
RX-GC50AP201

Revision: **1.3**

Page 7 of 12

4. Optical-Electrical Specifications

4.1. Begin-of-Life Specification

Table 4.1, BOL Specification

Item	Parameter	Symbol	Comments	Min	Max	Unit
1	Responsivity of individual tributaries ¹⁾	R_{avg}		50		mA/W
2	Responsivity imbalance between tributaries ²⁾	ΔR_{avg}			1.0	dB
3	P/N Responsivity imbalance (CMRR _{DC}) ³⁾	ΔR_{PN}	For Signal and LO path,		0.8	dB
4	Photodiode dark current	I_{Dark}	Per photodiode at typical V_{PD} and $T_{case} = 65^{\circ}\text{C}$		50	nA

Notes:

1. This is the worst case responsivity of one individual tributary from LO or Signal input, to one of four outputs, thus including inherent and excess loss. The responsivity is to be averaged over the P and N components of each tributary. To measure the average responsivity of the Signal path, a **polarization scrambled signal** shall be used.
2. Imbalance between XI, XQ, YI, YQ channels, for signal and LO path. The individual tributary's P/N responsivity has to be averaged.
3. Imbalance between P/N pair of one tributary for Signal and LO path. The imbalance is related to CMRR_{DC}. The Definition of CMRR_{DC} is:

$$CMRR_{DC} = 20 \times \log\left(\frac{|I_p - I_n|}{|I_p + I_n|}\right)$$

I_p is current of photodiode connected to the non-inverting input of the TIA.

I_n is current of photodiode connected to the inverting input of the TIA.



48500 Kato Road
Fremont, CA 94538 USA

Product Specification

2x8 Coherent Mixer with Single-Ended PD Output

Part No.:
RX-GC50AP201

Revision: **1.3**

Page 8 of 12

4.2. End-of-Life (EOL) Optical Specification

Table 4.2, Optical Specification (EOL)

Item	Parameter	Symbol	Comments	Min	Typ	Max	Unit
1	Operating Wavelength Range	λ	C-Band	1525		1568	nm
2	Tributary path delay	ΔT_{path}	Maximum skew between any path (XI, XQ, YI and YQ), Note 1	-		20	ps
3	Tributary path delay variation	ΔT_{var}	Skew variation over operating conditions and aging			5	ps
4	P/N path delay imbalance	ΔT_{bal}	Between balanced pairs, over operating conditions and aging	-		2	ps
5	Phase angle error	θ_m	Deviation from 90° angle between I and Q	-5		+5	degree
6	Polarization extinction ratio	PER	To be measured over photocurrents	20			dB
7	Optical return loss	RL	Each input	27			dB
8	Responsivity of individual tributaries ²⁾	R_{avg}		45			mA/W
9	Responsivity variation of individual tributaries over temperature	ΔR_{Temp}	Over operating case temperature range			1.0	dB
10	P/N Responsivity imbalance ³⁾	ΔR_{PN}	For Signal and LO path,			0.85	dB
11	Responsivity imbalance between tributaries ⁴⁾	ΔR_{avg}				1.0	dB

Notes

1. Overall delay between signal input or LO input and the respective electrical output. TIA gain set to medium gain. Use a heterodyne measurement setup. Sweep the beat frequency from 0.1 – 10 GHz and derive the phase response between any path (XI, XQ, YI and YQ).
2. This is the worst case responsivity of one individual tributary from LO or Signal input, to one of four outputs, thus including inherent and excess loss. The responsivity is to be averaged over the P and N components of each tributary. To measure the average responsivity of the Signal path, a **polarization scrambled signal** shall be used.
3. Imbalance between P/N pair of one tributary for Signal and LO path. The imbalance is related to CMRR_DC. The definition of CMRR_DC is:

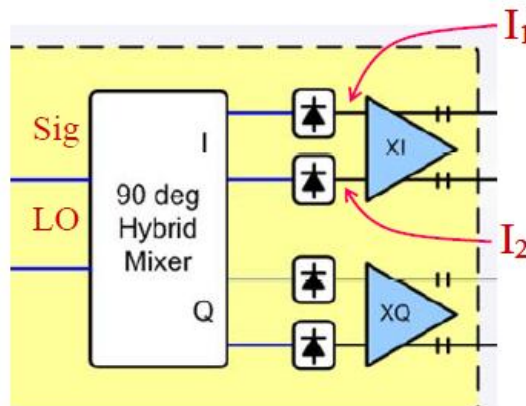

$$\text{CMRR (electrical)} = 20 \log \left[\frac{|I_1 - I_2|}{(I_1 + I_2)} \right]$$

Figure 4.1, CMRR Definition

$$\text{CMRR} = 20 \times \log \left(\frac{|I_p - I_n|}{|I_p + I_n|} \right)$$

I_p is current of photodiode connected to the noninverting input of the TIA,
 I_n is current of photodiode connected to the inverting input of the TIA.

4. Imbalance between XI, XQ, YI, YQ channels, for signal and LO path. The individual tributary's P/N responsivity has to be averaged.



48500 Kato Road
Fremont, CA 94538 USA

Product Specification

2x8 Coherent Mixer with Single-Ended PD Output

Part No.:
RX-GC50AP201

Revision: **1.3**

Page 10 of 12

4.3 PD Characteristics

Table 4.3, Characteristics of Photodiode

Parameter	Symbol	Min	Typ.	Max	Unit	Conditions
Active Diameter	D	300			μm	
Bandwidth	BW		0.6		GHz	$R_L=50\Omega$, $P_i=-10dBm$, $V_R=5V$
Responsivity	R	0.8			A/W	$\lambda = 1310\text{ nm}$, $V_R = 5V$
		0.9				$\lambda = 1550\text{ nm}$, $V_R = 5V$
Dark current	I_D			600	pA	$V_R = 5V$
Total Capacitance	C_t			6	pF	$V_R = 5V$, $f = 1MHz$

(Note: The PD used in this design is Kyosemi KPDE030-S)

5. Physical Requirements

5.1 Mechanical Drawing

(unit: *mm*)

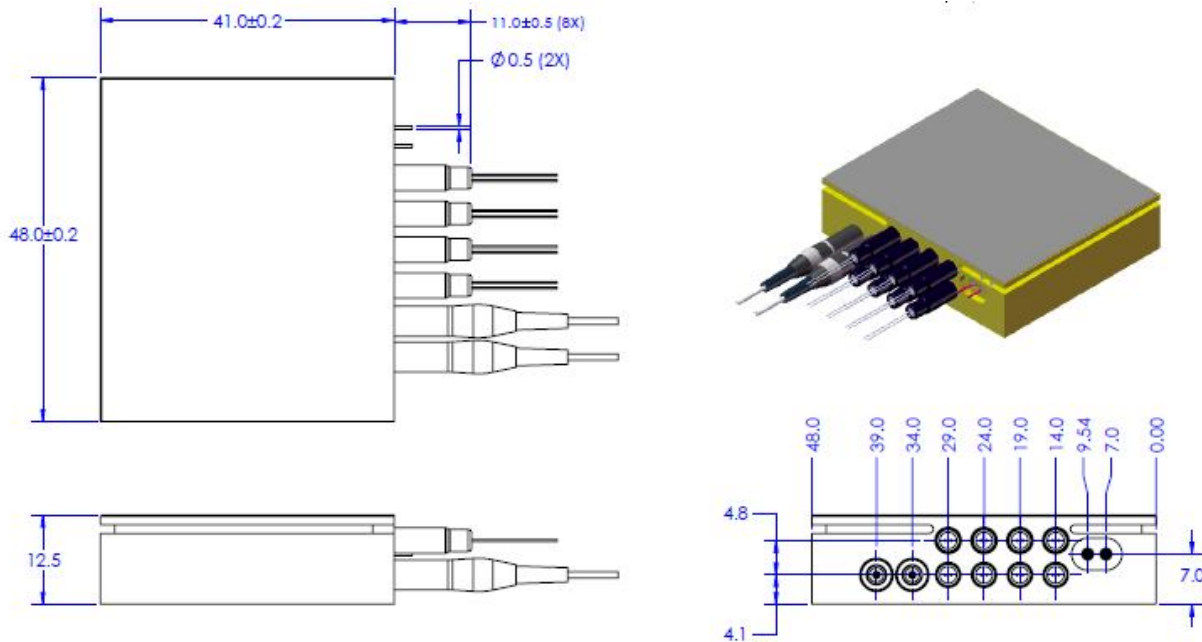

Figure 5.1, Mechanical Drawing of the 2x8 Coherent Receiver

5.2 Port Assignment

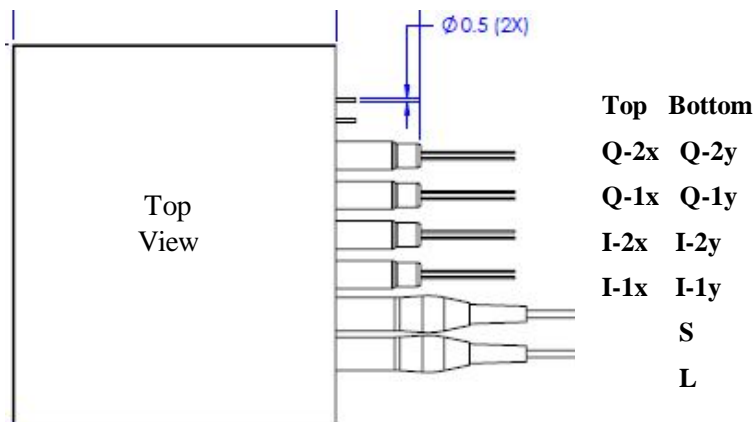

Figure 5.2, Illustration of the Port Assignment



48500 Kato Road
Fremont, CA 94538 USA

Product Specification

2x8 Coherent Mixer with Single-Ended PD Output

Part No.:
RX-GC50AP201

Revision: **1.3**

Page 12 of 12

5.3 Fiber and Pigtail Requirements

Table 5.1, Requirements of Fiber, Pigtail and Connector

Item	Parameter	Unit	Lo-Input	Signal Input
1	Fiber type	/	PANDA Type PMF	SMF-28 or Equivalent
2	Pigtail Type	/	900um loose tube	900um tight buffer
3	Pigtail length	m	1.0 +/- 0.1	1.0 +/- 0.1
4	Optical connector type	/	FC/APC	FC/APC
5	Fiber Label	/	Lo	Si

6. Label Requirements

6.1 Port label position and type — Flag tape on pigtail near connector. Width of tape: ~3 mm.

6.2 Port label contents — See above diagram.

6.3 Device label — On top, contains the following information:

- Optoplex logo
- Product description: **Coherent Mixer with Single-Ended Output**
- Manufacturer P/N: **RX-GC50AP201**
- Manufacturer S/N:

7. Quality and Reliability

RoHS 6/6 Compliant.

The reliability is same as the existing 2x8 coherent mixer with collimator outputs, which is qualified against Telcordia GR-1221-CORE.

Same photodiodes had been used in Optoplex's integrated 40G and 100G receivers (40G DPSK, 40G DQPSK, 40G and 100G ICR) as monitoring photodiode (MPD). Those integrated receivers were qualified against Telcordia GR-468-CORE.

The special 2x4 coherent receiver described in this document is considered qualified by similarity.